

Lake of the Woods County

Mailbox Support Installation Instructions

Supplies

1. Mailbox Support
2. 6' Sign Post
3. 2 Sign Post Bolts
4. Marking Stake (for One-Call)

1. It is very important to install your mailbox support carefully so that snowplow wings can move snow out from under the mailbox and, at the same time, allow access for the mail carrier.
2. **Prior** to installing the mailbox support, you should carefully measure **48"** from the outside edge of the road shoulder and place a marking stake at this location. Then call the Gopher One-Call number at 1-800-252-1166 to request a locate for possible buried utilities, such as telephone or electric wires, before driving the sign post.
3. If there are no underground utilities at your stake location, drive in your sign post, leaving at least two feet (2') out of the ground (more if the inslope is steep). Make sure the sign post face is parallel with the road.
4. Adjust the mailbox support so that the bottom of the mailbox will be **45"** above the road shoulder and install the two sign post bolts. This height minimizes snowplow strikes.
5. You can now bolt or screw your mailbox onto the support brackets.
6. If you also have a plastic newspaper box, please attach this to the side of your mailbox.

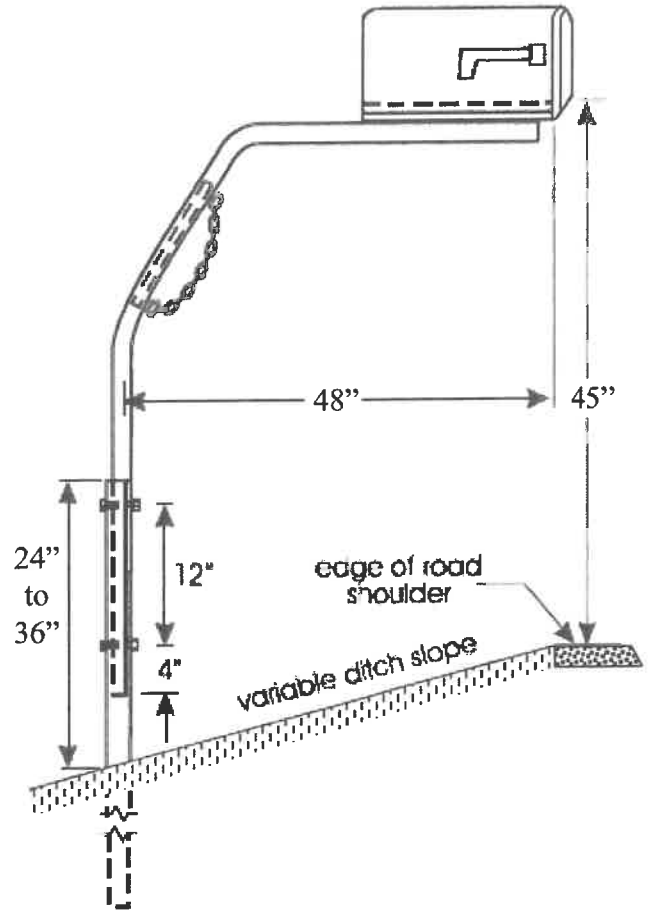

I hereby certify that I am a resident of Lake of the Woods County, and that I live on a County road, and I will install the mailbox support according to the above instructions.

Name: _____
 Address: _____

County Road No. _____

Signature

Date